

**City of Barberton**  
**ROAD & RIGHT OF WAY**  
**OPENING, BORING, WORK**  
**PERMIT**

Permit # \_\_\_\_\_

<b>Applicant Name:</b>	
<b>Applicant Address:</b>	
<b>Applicant Phone:</b>	<b>Fax:</b> <b>E-mail:</b>
<b>Project Address or Area:</b>	
<b>Contractor Name:</b>	
<b>Contractor Address:</b>	
<b>Contractor Phone:</b>	<b>Fax:</b> <b>E-mail:</b>
<b>REASON FOR OPENING</b>	<b>REASON FOR BORING</b>
Sanitary Connection	Sanitary Connection
Storm Sewer Connection	Storm Sewer Connection
Water Service Connection	Water Service Connection
Gas Connection	Gas Connection
Cable /Fiber Optics	Cable/Fiber Optics

**RIGHT OF WAY WORK**

Drive Approach	Tree Removal	Curb Collector
Curb Cut	Utility Pole	Open Road Cut
Sidewalk	Culvert	

**PLEASE NOTE: A \$50 PER PARCEL FEE WILL BE REQUIRED PRIOR TO ISSUANCE OF A PERMIT. A COPY OF CONSTRUCTION PLAN FOR REVIEW MUST ACCOMPANY APPLICATION AND FEE BEFORE IT WILL BE CONSIDERED.**

**NUMBER OF PARCELS AFFECTED \_\_\_\_\_ NUMBER OF ROADS AFFECTED \_\_\_\_\_  
 WORK TO START ON OR ABOUT \_\_\_\_\_ AND WILL REQUIRE \_\_\_\_\_ DAYS.  
 THE OPENING TO BE \_\_\_\_\_ FEET LONG BY \_\_\_\_\_ FEET WIDE AND \_\_\_\_\_ FEET DEEP.**

Application is made for permission to enter a City of Barberton Street or Right of Way as indicated and in accordance with the following conditions and standards as outlined in Barberton Codified Ordinance Section 1020 and Ordinance 144-2015.

- a. That all work shall be done in accordance with City rules, regulations and standards; shall be first class in every manner and subject to City inspection and to the approval of authorized officer of the City of Barberton. All materials and work must conform to the City of Barberton standard details for street and utilities. (attached)
- b. The Contractor is responsible that all excavations will be backfilled and a temporary or the final pavement installed the same day as the original opening, steel plates may be used to protect the excavation if the final pavement is installed the day following the original opening.
- c. The work site will be protected with bracing, barricades and lights per OSHA regulations and traffic control in accordance with Ohio Manual of Uniform Traffic Control Devices. The applicant

hereunder shall save the City and its agents harmless from any and all damage or injury resulting from the prosecution of the work.

- d. Road openings must commence within ten (10) days of the approved permit and the roadway may not be open for more than five (5) days.
- e. That the applicant waive any and all damage he may sustain by reason of the work allowed under this permit; and, further this permit not operate as a waiver of assessment for sewerage or waterlines constructed in village roads upon which the premises abut.
- f. Notify the utility owner when ready to make sanitary, gas, water or storm sewer tap and do not cover work until it has been inspected and approved.
- g. Contact the City of Barberton at 330-848-6724 to request a new water service and an inspection (unless a well will be installed). Back up number 330-848-8747
- h. Contact the City of Barberton at 330-848-6724 to obtain a sanitary sewer permit and coordinate the required inspection. Back up number 330-745-1864
- i. The City must be present to observe storm sewer connections as well as the backfilling, compaction, and pavement replacement operations for all work within the Right of Way.
- j. **Keep this permit on the work site. Provide 48-hour notice for all City inspections.**
- k. Water and sewer service lines must be ten (10) feet apart
- l. Failure to observe these rules will result in forfeiture of permit and remedy of conditions by the City of Barberton forces at owner's expense.
- m. A deposit in the amount of \$70/sq. ft. (min. of \$2,000) for asphalt roads and \$100/sq. ft. (min. of \$2,500) for concrete roads and main roads is required for each opening. Sidewalk deposit shall be \$10/sq. ft. (min. of \$1,000). If unpaved, deposit to be \$1,000.

**ACKNOWLEDGEMENT**

I the applicant, hereby acknowledge that I have read and understand the City of Barberton Street Opening, Road Boring and Right of Way provisions and standards, as outlined in the application as well as the road and utility standards and will comply with these policies and provisions. I understand that non-compliance with the provisions and standards will result in revocation of the permit and partial or complete forfeiture of any fees, cash deposit or will result in a claim against my bond.

In order to protect the interest of the City, an inspector may be assigned full time to the job by the City of Barberton at the expense of the applicant. The permit is valid for ninety (90) days (six months for Sanitary Sewer Excavation), after which a new permit must be sought and reissued. Any extension of the normal permit validity period must be in writing.

The City requires a minimum of **48 HOUR NOTICE PRIOR TO CONSTRUCTION STARTING**, for safety and inspection purposes.  
**THE CITY RESERVES THE RIGHT TO REQUIRE A PRECONSTRUCTION MEETING PRIOR TO THE BEGINNING OF A PROJECT.**

Applicant Signature: \_\_\_\_\_ Date: \_\_\_\_\_

Permit Fee: \$ \_\_\_\_\_ Receipt #: \_\_\_\_\_ Paid by Cash or Credit Card \_\_\_\_\_

Amount of Deposit Required: \_\_\_\_\_ Copy of Ins. Cert. with City named as Additional Insured \_\_\_\_\_

Preconstruction meeting required Yes or No \_\_\_\_\_ Date of meeting \_\_\_\_\_

PERMIT APPLICATION DATE: \_\_\_\_\_ PERMIT EXPIRATION DATE \_\_\_\_\_

PERMIT ISSUED BY: \_\_\_\_\_ Date: \_\_\_\_\_

Deposit Release Date: \_\_\_\_\_ Inspector Approving Release: \_\_\_\_\_

**1020.01 PERMIT REQUIRED; FEE; LIABILITY INSURANCE; EXEMPTION.**

(a) No person, other than a duly authorized officer or employee of the City, shall make an excavation in any street, alley, sidewalk or public ground for any purpose whatever unless he or she has obtained a permit in writing therefor from the City Engineer and unless he or she has paid a uniform fee of fifteen dollars (\$15.00) for each and every such permit issued.

(b) No person shall make an excavation in any street, alley, sidewalk or public ground for any purpose whatever until such person has filed with the Director of Public Service a public liability policy, indemnifying the City and its officials, in the sum of three hundred thousand dollars (\$300,000) for the injury or death of any person and one hundred thousand dollars (\$100,000) for property damage. The only exemption will be homeowners doing their own sidewalk and/or driveway apron installation and/or repairs. Homeowners must sign a disclaimer acknowledging responsibility for damages to all public and private utilities.

(Ord. 144-1998. Passed 7-27-98.)

**1020.02 CASH DEPOSIT REQUIRED.**

Any person to whom a permit is granted, under Section 1020.01, shall furnish a cash deposit approved by the Director of Public Service to cover the cost of filling such excavation and of restoring to its former condition such street, alley, sidewalk or public ground where the same has been excavated, and for the payment of all expenses, if any, incurred by the City in replacing or supplying the material disturbed or removed by such excavation. (Ord. 38-1955. Passed 4-4-55.)

**1020.03 RESPONSIBILITY OF PARTIES; STREET CLASSIFICATIONS; RESTORATION CHARGES.**

(a) Street opening permits shall not be issued to a property owner unless such property owner is utilizing his or her own labor and equipment in making the street opening. If a contractor is to perform the work, it will be the responsibility of the contractor to obtain the necessary permit.

(b) Streets are divided into two classes only, as follows:

(1) Improved streets. This class includes all streets having a brick, concrete, asphalt, macadam or stabilized surface, as well as those streets which have received a seal coat or temporary surfacing.

(2) Unimproved streets. This class includes all streets having a dirt, cinder or gravel surface, even though such streets may have received applications of oil or calcium chloride for control of dust. Utility companies, contractors or individuals shall be charged a flat charge for such permits, based on the area of the opening to be made and the type of street surface.

(c) A flat charge shall apply to all street openings having an area of one to five square yards. Openings having an area of less than one square yard shall be considered as being one square yard and shall be charged accordingly. Openings having an area in excess of five square yards shall be handled by mutual agreement between the utility, contractor or individual and the Director of Public Service, the City Engineer and the Superintendent of Streets. A permit charge of fifteen dollars (\$15.00) shall be made for all applications for street openings as provided in Section 1020.01.

(d) The flat charge for restoration of street surfaces shall be as follows:

(1) Improved streets. A fifteen dollar (\$15.00) permit charge, plus three dollars (\$3.00) per square foot area of opening.

(2) Unimproved streets. A fifteen dollar (\$15.00) permit charge, plus two dollars (\$2.00) per square foot area of opening.

(e) All charges required to be deposited, pursuant to the provisions of this chapter, shall be deposited with the City Treasurer.

(f) Utility companies holding a franchise with the City are exempt from paying the fifteen dollar (\$15.00) permit charge. They shall, however, pay the restoration costs as specified above. (Ord. 89-1992. Passed 6-8-92.)

#### **1020.04 INSPECTION CHARGES.**

(a) The Division of Engineering shall make an inspection charge in the case of restoration work done by a utility, contractor or individual, but no inspection charge shall be made on restoration work done by the City.

(Ord. 231-1974. Passed 7-1-74.)

(b) On openings of such size that an inspector is required to be present continually, the permittee shall be charged as determined by the Director of Public Service. (Ord. 38-1955. Passed 4-4-55.)

#### **1020.05 CONTRACTS WITH CITY.**

Contracts under the supervision of any City department which involve an opening in a street must contain as a part of their contract specifications a reference to this chapter, and such departments shall require their contractors to secure a permit and perform all work in connection with such an opening in accordance with the provisions of this chapter. (Ord. 38-1955. Passed 4-4-55.)

#### **1020.06 PREREQUISITES TO ISSUANCE OF PERMITS.**

(a) Street opening permits shall be issued by the Division of Engineering upon payment of the permit fee and restoration charge. (Ord. 231-1974. Passed 7-1-74.)

(b) Permits shall be issued only for openings to be made within thirty days from the date of issue. The period of time allowed for closing the opening shall be governed by its size, nature and location and by weather conditions. All applications for mains, conduits, manholes and other subsurface structures of considerable magnitude shall be accompanied by a plan and typical cross section, which shall show, as nearly as possible from records available, the location of the existing underground structures and the location of the proposed structure. A permit shall be issued when one of the following provisions is involved:

(1) The applicant has made a cash deposit equal to the charge for restoration and inspection;

(2) The applicant is a contractor for the City on a contract involving the opening of streets, in which case he may obtain a permit without a cash deposit. However, the restoration work, if done by such contractor, must be approved by the Director of Public Service and all inspection charges must be paid before such contractor receives his final estimate. If the restoration work is done by the City, all such charges against the contractor must be paid before he receives his final estimate;

(3) The applicant is a City, County or State department or division whose functions require the installation and maintenance of underground structures; or

(4) The applicant is a corporation whose franchise authorizes it to make its own restoration. Such permits will be issued only when the restoration work keeps fully apace with the openings being made. Such corporation must pay promptly all bills for inspection by the City and all bills for restoration if it desires to avail itself of the facilities of the City for restoring pavements.

(Ord. 38-1955. Passed 4-4-55.)

#### **1020.07 NOTIFICATION OF WORK; STREET CLOSINGS.**

(a) The permittee shall notify the Division of Engineering when the opening is to be made, when backfilling is to commence, when temporary restoration has been made and when permanent restoration can be made. (Ord. 231-1974. Passed 7-1-74.)

(b) If it is necessary to close a street completely and detour traffic, at least forty-eight hours advance notice shall be given the Director of Public Service. The Police and Fire Divisions shall also be notified whenever a street is to be closed or whenever the work may interfere with their functions.

The permittee shall also notify all utility companies that may be concerned by reason of adjacent installations. (Ord. 38-1955, Passed 4-4-55.)

**1020.08 GENERAL PROCEDURE.**

(a) The permittee must carry out the work authorized by the permit in such a manner as to cause a minimum of interference with traffic of all kinds. On main thoroughfares and in the congested districts there must be sufficient traffic lanes open to permit a substantially normal traffic flow or else the work hours must be between 7:00 p. m. and 7:00 a. m. of the following day. In case of a special emergency, a serious leak or a major impairment of service, it will be necessary to make special arrangements so that police officers may be assigned to handle traffic.

(b) When it is necessary to close a street completely and detour traffic, special arrangements with the Director of Public Service must be made in advance. Every person making openings in City streets shall keep the Director informed as to whom to call in case of emergencies, such as settlements or washouts resulting from severe storms.

(c) Access to fire hydrants must be provided at all times. Gutters and catch basins must be kept open and drainage maintained as far as possible. When it is necessary to close a gutter or cut off a catch basin, drainage must be maintained by the use of pumps, flumes or culverts.

(d) Tools, equipment, shanties and materials must be stored at locations where they will cause the least inconvenience to traffic and adjoining property. Walks, driveways and entrances to buildings must be kept open. Steel plates of adequate size shall be furnished to cover small paving cuts and to provide crossings over trenches on main thoroughfares and at important intersections. The plates shall be securely fastened in place to prevent movement under traffic. If necessary, temporary walks or bridges shall be provided for pedestrians.

(e) All openings in streets, alleys or other public places shall be protected by suitable barricades, fences or railings. Sufficient and suitable red or amber lights or torches shall be provided to indicate clearly all openings, equipment, materials or other hazards that might cause an accident.

(f) Slightly and sufficient sanitary conveniences for the use of workmen on the job, properly secluded from public observation, shall be provided and maintained in a sanitary condition.

(g) Excavated materials shall be promptly removed and disposed of when the materials are not suitable for backfill or when, due to the location of the work, there is not sufficient room to permit the storing of the excavated materials. When the storage of excavated materials is permitted at the site of the work, such materials shall be compactly piled, using plank bins or retaining walls if necessary, to prevent dirt from spreading over the pavements.

(h) Lawns, trees and other vegetation shall be protected from damage. Trees must not be removed or disturbed except with the approval of the Director and his instructions regarding the laying of pipes or conduits under trees shall be followed.

(i) Whenever it is necessary to cross over or under work close to other utility installations, such as tracks, mains, ducts, pipes, etc., notification must be given to that utility and it shall be the duty of the applicant to properly protect such other utility property in a safe condition so that the public may not be endangered or unnecessarily inconvenienced. All trenches and tunnels shall be braced to protect workmen, the public and property. This bracing shall be sufficient to protect all surface and subsurface structures and to prevent the undermining of adjacent

pavement, curbs and sidewalks. House connections, water mains, gas mains, conduit lines and drain pipe shall be supported across trenches.

(j) A permit for drawing water from fire hydrants must be secured from the Division of Utilities.

(k) The permittee shall comply with the rules of the Division of Utilities governing the furnishing of water from the City mains.

(Ord. 38-1955. Passed 4-4-55.)

#### **1020.09 TRENCHING, TUNNELING AND BACKFILLING.**

(a) The length, width and location of a trench and the manner in which the work is done shall be under the control of the City.

(b) If, in excavating a trench or laying pipe and appurtenances, the pavement along the sides of the trench is or becomes undermined and unsupported, such pavement shall be broken down, removed and replaced at the expense of the permittee.

(c) The opening cut through the pavement must be eight inches from the edges of the trench in all directions so that the new pavement base will have a suitable bearing on firm and undisturbed ground. If the sides of the trench cave in after the opening through the pavement has been made, such opening in the pavement shall be enlarged in order to provide the required eight inches of bearing surface.

(d) Tunneling may be necessary in certain locations. However, the permittee shall not do any tunneling except by permission from the City. If City departments do the tunneling, they shall notify the Division of Streets of the same and shall be subject to the same requirements regarding backfilling as permittees.

(e) When tunneling has been done, the permittee shall backfill the tunnel, except as noted below, with a mixture of sand, gravel and cement in the proportion of one bag of cement to not over twenty cubic feet of aggregate. The mixture shall be of such consistency that it will hold together when formed into a ball in the hands.

(f) Around the pipe and for a distance of not more than twelve inches above the top of the pipe, fine material wetted and tamped or well compacted clay may be used.

(g) During the period from December 1 to March 31, or during freezing weather at any other time, the backfilling of all openings in paved streets or alleys shall be made with sand, bank run gravel or other fine granular material, all of which shall be free of frost or excess moisture and thoroughly compacted.

(h) During the period from April 1 to November 30, the excavated material, if suitable and in proper condition, may be used for backfilling.

(i) Under no circumstances shall wet clay, silt or similar material be used for back-filling within the area of any City street.

(j) Loose, broken rock shall not be considered suitable backfill material unless sufficient fine material is added to more than fill the voids.

(k) All backfilled trenches shall be consolidated either by flushing or power tamping, depending upon the nature of the material used.

(Ord. 38-1955. Passed 4-4-55.)

#### **1020.10 TEMPORARY AND PERMANENT RESTORATIONS.**

(a) Temporary restorations shall be made by the permittee in accordance with the requirements of Section 1020.14, and the permittee shall be responsible for maintaining the backfilled opening in a safe and usable condition until such time as the permanent restoration can be made. Until the openings have been taken over by the Division of Streets for permanent

restoration, each permittee shall, after each heavy rain and during thawing periods, check over all openings and temporary restorations made by him and shall make such repairs as may be necessary or, if such repairs cannot be promptly made, shall provide barricades and lights for the protection of the public.

(b) Complete restoration, including pavement base and surface, may be done by the Division of Streets after the permittee has completed the backfill and made temporary restoration to the satisfaction of the Director of Public Service.

(c) Partial restoration up to and including the pavement base may be done by the permittee subject to the Director's approval. All such work must conform to the current edition of the State of Ohio, Department of Transportation, Construction and Material Specifications.

(d) Unless otherwise ordered, the permittee shall make complete restoration of all unpaved areas in accordance with the requirements of Section 1020.11.

(e) The permittee may, in some cases, be able to arrange for the Division of Streets to do the work referred to in subsection (d) hereof at the expense of the permittee. (Ord. 38-1955. Passed 4-4-55.)

#### **1020.11 RESTORATION OF UNPAVED AREAS.**

Upon completion of the underground work, the permittee shall promptly restore all unpaved areas to their former condition as far as possible. All excess dirt shall be removed and disposed of; all ditches shall be cleaned; drainage structures shall be restored and left in an operating condition; dirt streets shall be left in a smooth usable condition; cinder or gravel surfaces shall be restored; if surfaces have been treated with dust laying or other bituminous materials, the same shall be replaced; all lawn strips or sodded areas shall be replaced; and all sidewalks and driveways shall be replaced. Patching of sidewalk blocks is not permitted and the replacement of the entire block is required.

(Ord. 38-1955. Passed 4-4-55.)

#### **1020.12 RESTORATION OF PAVED AREAS.**

All paved areas, together with the adjacent curbs, manhole and valve box castings and any other appurtenances within the street, shall be restored by one of the methods mentioned in this chapter. So far as practicable, the restored base and surface shall be of the type existing before the openings were made except that when concrete is used for restoring the base course, the new concrete base shall not be less than eight inches thick, regardless of whether or not a base course of such thickness or mixture existed at the time the pavement opening was made.

In the case of streets having stabilized base courses or macadam base courses, the Division of Streets reserves the option of substituting penetration macadam base course and premixed bituminous surface course for restoration purposes or concrete base and bituminous surface course. In all other cases, the original type of surface material is to be used.

The permittee responsible for the opening shall be charged the actual cost plus fifteen percent of all labor, material and equipment required to restore the pavement and appurtenances. The City shall charge only for the area actually disturbed due to the pavement opening or for disturbances resulting therefrom.

When the permittee makes the backfill, he shall be held responsible for any settlement. No time limit shall be considered as releasing him from this obligation.

(Ord. 38-1955. Passed 4-4-55.)

#### **1020.13 MATERIAL TO BE DEPOSITED SO AS NOT TO INCONVENIENCE PUBLIC.**

In removing pavement or other material from streets, alleys, sidewalks or public grounds, for any purpose whatever, the material dug up must be deposited in such manner as to guard against

inconvenience to the public by obstructing streets, alleys, sidewalks or public grounds. (Ord. 38-1955. Passed 4-4-55.)

**1020.14 RESTORATION OF SURFACE; COSTS.**

All places where pavement or other material is removed from streets, alleys, sidewalks or public grounds shall be restored to their former condition as soon as practicable, either by the City or by the person causing such pavement to be removed, as may be directed by the Director of Public Service. The cost shall be paid by the person causing such pavement to be removed or, in default thereof, shall be deducted from the cash deposit referred to in Section 1020.02. (Ord. 38-1955. Passed 4-4-55.)

**1020.15 GUARDING EXCAVATIONS; SIGNAL LIGHTS.**

No excavation or hole in any street, alley, sidewalk or public ground shall be left open and unguarded or without signal lights during the night time.

(Ord. 38-1955. Passed 4-4-55.)

**1020.16 TRANSPORTATION OF MATERIALS OVER STREETS; DEPOSIT REQUIRED.**

No contractor, hauler or builder shall transport earth, sand or gravel over any paved street of the City without first making a cash deposit with the Director of Public Service. Such deposit shall consist of cash, in an amount not exceeding one hundred dollars (\$100.00), to be determined by the Director, and shall be a guarantee that such contractor, hauler or builder will clean the street of any earth, sand or gravel which may fall from his vehicle. If such contractor, hauler or builder fails to clean such street, then the City will do so and deduct the cost of such work from the money deposited as herein required, returning the balance remaining, if any, to the contractor, hauler or builder making the deposit. (Ord. 1929 Code, Sec. 322)

**1020.17 TRAFFIC CONTROL.**

(a) No person shall commence the performance of any work involving the opening, closing, blocking, excavating, repairing, tearing up, digging or otherwise blocking of any street so as to change the normal course of traffic on the street without first obtaining, from the Chief of Police, a permit for traffic control thereon.

(b) Such person shall apply to the Chief for a permit to implement traffic control according to a traffic control diagram which is to be submitted to the Chief and approved by the Chief prior to the issuance of such permit.

(c) Such traffic control diagram shall include therein a provision for the use of such flag persons or police officers as are necessary, in the judgment of the Chief, for the adequate and safe control of traffic at the construction site.

(d) Upon the issuance of such permit, the person to whom the permit is issued shall, at his or her own expense, install and maintain signs, warning devices, lights, barricades, drums, cones, flag persons or police officers, as shown on the traffic control diagram, and failure to install and maintain the same shall be grounds for the issuance of a stop order or revocation of the permit by the Chief and/or the revocation of any permit issued by the City.

(e) If travel and safety warrant it, the Chief of Police has the authority to request additional traffic control at the expense of the contractor.

(f) Authorized City repair workers are exempted from the provisions of this section.  
(Ord. 63-1993. Passed 5-10-93.)

**1020.99 PENALTY.**



Whoever violates any of the provisions of this chapter shall be fined not more than five hundred dollars (\$500.00) or imprisoned not more than six months, or both. A separate offense shall be deemed committed each day during or on which a violation occurs or continues.

(Ord. 261-1957. Passed 12-2-57.)

**Disclaimer:**

This Code of Ordinances and/or any other documents that appear on this site may not reflect the most current legislation adopted by the Municipality. American Legal Publishing Corporation provides these documents for informational purposes only. These documents should not be relied upon as the definitive authority for local legislation. Additionally, the formatting and pagination of the posted documents varies from the formatting and pagination of the official copy. The official printed copy of a Code of Ordinances should be consulted prior to any action being taken.

For further information regarding the official version of any of this Code of Ordinances or other documents posted on this site, please contact the Municipality directly or contact American Legal Publishing toll-free at 800-445-5588.

© 2016 American Legal Publishing Corporation  
[techsupport@amlegal.com](mailto:techsupport@amlegal.com)

SIDEWALK OR SEEDING & MULCHING, 4" TOPSOIL AND TYPE 1 SEED PER ODOT ITEM 659

BACK OF CURB/EDGE OF PAVEMENT

SUITABLE COMPACTED EXCAVATED MATERIAL, 12" MAX LIFT

DOWEL (TYP) IF EXISTING CONCRETE MORE THAN 7" THICK

ODOT ITEM 304, COMPACTED TO 95% MAX. DRY DENSITY - 12" MAX. LIFT OR ODOT ITEM 613, TYPE 1 LOW STRENGTH MORTAR.

**PAVEMENT NOTES:**

1. THICKNESSES SHOWN ARE MINIMUM. CONTRACTOR TO MATCH EXISTING PAVEMENT.
2. ALL AGGREGATES SHALL BE CRUSHED, VIRGIN LIMESTONE.

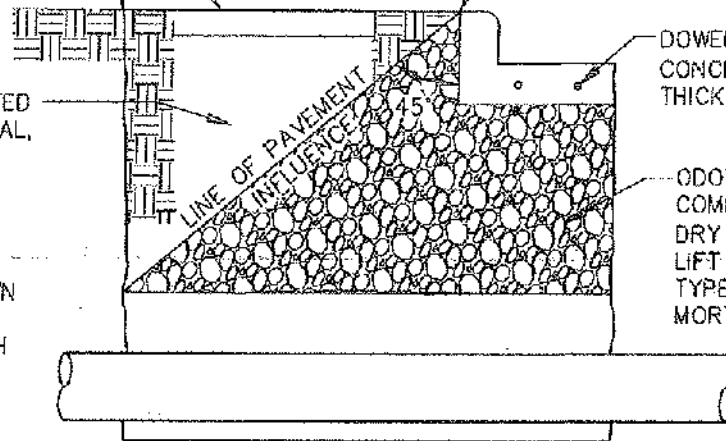

**TRENCH DETAIL**  
N.T.S.

REPLACE TO EXISTING JOINT IF JOINT IS WITHIN 3' OF REPAIR

DRILL 1 1/2" HOLE, 9" DEEP AND SECURE DOWELS WITH GROUT PER ODOT 705.20 BLOW OUT HOLES WITH COMPRESSED AIR PRIOR TO GROUTING. INSTALL GROUT RETENTION DISK PER ODOT DETAIL BP 2.5, 1.125" DIAMETER OPENING.

BITUMINOUS SEALER PER ODOT ITEM 705.04, ALL SIDES. CUT 1 1/2" DEEP X 1/4" WIDE GROOVE TO ACCEPT JOINT SEAL. SEAL FLUSH TO SURFACE.

EPOXY COATED 1" DOWEL, 18" LONG 12" C/C (CENTER IN SLAB) (6" MIN. FROM SIDES OF REPAIR)

NO. 6 WIRE FABRIC PER ODOT 709.10

SAW CUT EACH SIDE

1'-0" MIN. EACH SIDE

O.D.O.T. ITEM 451, 9" MIN. THICKNESS, MATCH EXISTING WITH CLASS MS CONC.

BACKFILL WITH ODOT ITEM 304, COMPACTED TO 95% MAX. DRY DENSITY - 12" MAX. LIFT OR ODOT ITEM 613, TYPE 1 LSM. EXTEND BEHIND CURB AT A 45° ANGLE. (SEE ABOVE)

COMPACTED BEDDING PER UTILITY OR USE #57 OR #67 ANGULAR AGGREGATE. NO SLAG.

12" MAX

d + 2' MIN.

NOTE: IF THE REPAIR IMPACTS AN EXISTING EXPANSION JOINT, THE JOINT MUST BE RE-ESTABLISHED PER ODOT STANDARD DETAILS.

**TYPICAL SECTION FOR REPAIRING CONCRETE ROADS**  
N.T.S.

CITY OF BARBERTON  
STANDARD DRAWING ROAD 1  
REVISION: 12/9/14

SIDEWALK OR SEEDING & MULCHING, 4" TOPSOIL AND TYPE 1 SEED PER ODOT ITEM 659

BACK OF CURB/EDGE OF PAVEMENT

SUITABLE COMPACTED EXCAVATED MATERIAL, 12" MAX LIFT

LINE OF PAVEMENT INFLUENCE 45°

ODOT ITEM 304, COMPACTED TO 95% MAX. DRY DENSITY - 12" MAX. LIFT OR ODOT ITEM 613, TYPE 1 LOW STRENGTH MORTAR.

PAVEMENT NOTES:

1. THICKNESSES SHOWN ARE MINIMUM. CONTRACTOR TO MATCH EXISTING PAVEMENT.

2. ALL AGGREGATES SHALL BE CRUSHED, VIRGIN LIMESTONE.

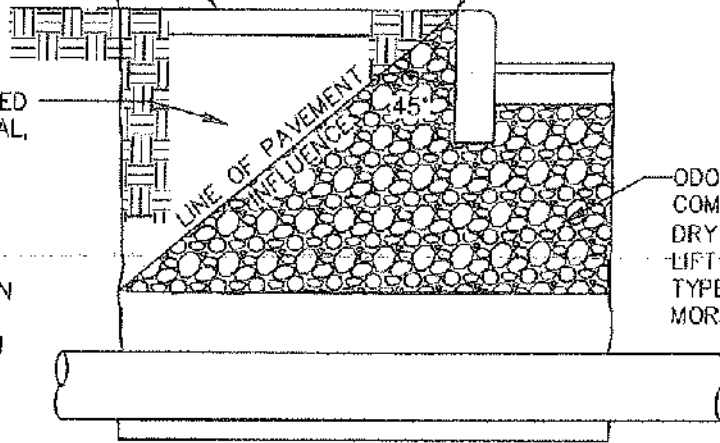

TRENCH DETAIL  
N.T.S.

BITUMINOUS SEALER PER ODOT ITEM 705.04 (ALL SIDES)

1 1/2" ODOT ITEM 448, TYPE 1, ASPHALT CONCRETE SURFACE COURSE

6" ODOT ITEM 301 ASPHALT CONCRETE BASE (IF LSM BACKFILL)  
8" ODOT ITEM 305 BASE (IF 304 BACKFILL)

6" ODOT ITEM 304 AGGREGATE BASE (NOT REQUIRED WITH LSM BACKFILL)

6" ODOT ITEM 402 TACK COAT @ 0.1 GAL/SQ.YD.

SAW CUT EACH SIDE

1'-0" MIN. EACH SIDE

COMPACTED BEDDING PER UTILITY OR USE #57 OR #67 ANGULAR AGGREGATE. NO SLAG.

BACKFILL WITH ODOT ITEM 304, COMPACTED TO 95% MAX. DRY DENSITY - 12" MAX. LIFT OR ODOT ITEM 613, TYPE 1 LSM. EXTEND BEHIND CURB AT A 45° ANGLE. (SEE ABOVE)

12" MAX

d + 2' MIN.

TYPICAL SECTION FOR REPAIRING ASPHALT SURFACE AND ASPHALT BASE ROADS

N.T.S.

CITY OF BARBERTON  
STANDARD DRAWING ROAD 2  
REVISION: 12/9/14

SIDEWALK OR SEEDING & MULCHING, 4" TOPSOIL AND TYPE 1 SEED PER ODOT ITEM 659

BACK OF CURB/EDGE OF PAVEMENT

SUITABLE COMPACTED EXCAVATED MATERIAL, 12" MAX LIFT

DOWEL (TYP) IF EXISTING CONCRETE MORE THAN 7" THICK

ODOT ITEM 304, COMPACTED TO 95% MAX. DRY DENSITY - 12" MAX. LIFT OR ODOT ITEM 613, TYPE 1 LOW STRENGTH MORTAR.

PAVEMENT NOTES:

1. THICKNESSES SHOWN ARE MINIMUM. CONTRACTOR TO MATCH EXISTING PAVEMENT.
2. ALL AGGREGATES SHALL BE CRUSHED, VIRGIN LIMESTONE.

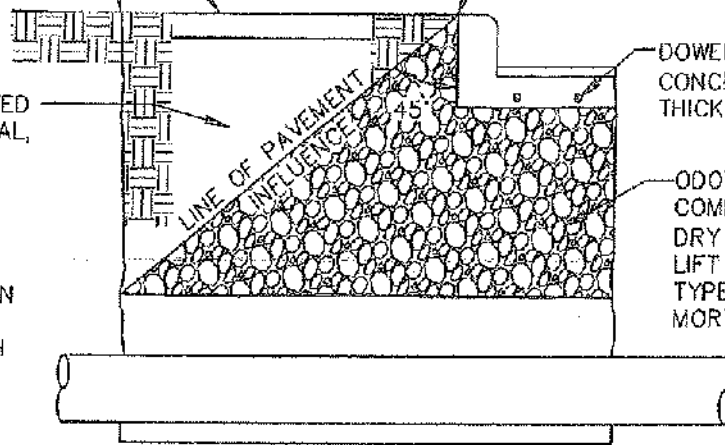

TRENCH DETAIL  
N.T.S.

ODOT ITEM 402 TACK COAT @ 0.1 GAL./SQ. YD.

1 1/2" ODOT ITEM 448, TYPE 1, ASPHALT CONCRETE SURFACE COURSE

BITUMINOUS SEALER PER ODOT ITEM 705.04 (ALL SIDES)

8" ODOT ITEM 305 PORTLAND CEMENT, TYPE MS CONCRETE BASE

NO. 6 WIRE FABRIC AS PER 709.10

EPOXY COATED 1" DOWEL, 18" LONG 12" C/C (CENTER IN SLAB) (6" MIN. FROM SIDES OF REPAIR)

DRILL 1 1/2" HOLE, 9" DEEP AND SECURE DOWELS WITH GROUT PER ODOT 705.20 BLOW OUT HOLES WITH COMPRESSED AIR PRIOR TO GROUTING. INSTALL GROUT RETENTION DISK PER ODOT DETAIL BP 2.5, 1.125" DIAMETER OPENING.

SAW CUT EACH SIDE

12" MAX

1'-0" MIN. EACH SIDE

COMPACTED BEDDING PER UTILITY OR USE #57 OR #67 ANGULAR AGGREGATE. NO SLAG.

BACKFILL WITH ODOT ITEM 304, COMPACTED TO 95% MAX. DRY DENSITY - 12" MAX. LIFT OR ODOT ITEM 613, TYPE 1 LSM. EXTEND BEHIND CURB AT A 45° ANGLE. (SEE ABOVE)

d + 2' MIN.

NOTE: IF THE REPAIR IMPACTS AN EXISTING EXPANSION JOINT, THE JOINT MUST BE RE-ESTABLISHED PER ODOT STANDARD DETAILS.

ASPHALT SURFACE OVER CEMENT CONCRETE BASE ROAD  
N.T.S

CITY OF BARBERTON  
STANDARD DRAWING ROAD 3  
REVISION: 12/9/14

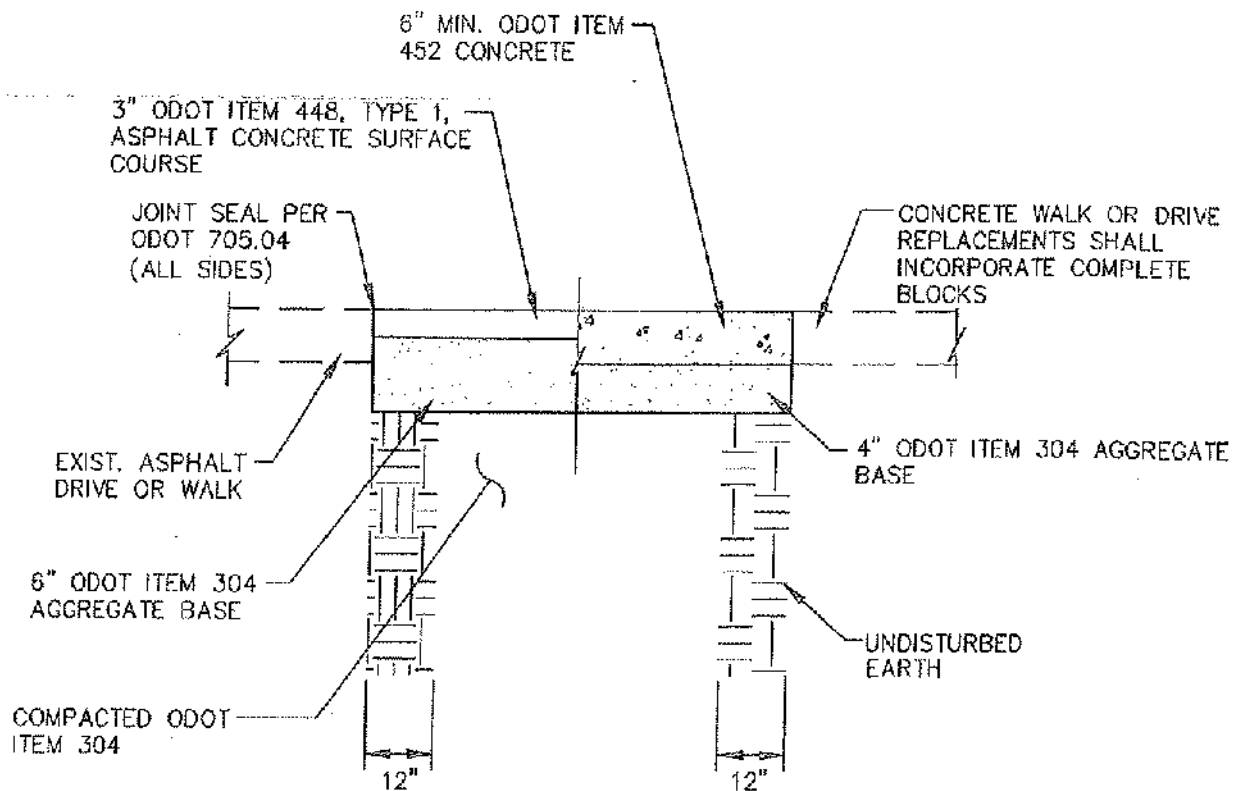

GENERAL PAVEMENT NOTE:

1. WHERE EDGES OF REPLACED SECTION EXTENDS WITHIN 2'-0" OF DRIVEWAY EDGE, PAVEMENT IS TO BE REPLACED TO DRIVEWAY EDGE.
2. THICKNESSES SHOWN ARE MINIMUM. CONTRACTOR TO MATCH EXISTING PAVEMENT.
3. ALL AGGREGATES SHALL BE CRUSHED, VIRGIN LIMESTONE.

RESIDENTIAL ASPHALT OR CONCRETE DRIVEWAY REPAIR  
N.T.S

CITY OF BARBERTON  
STANDARD DRAWING ROAD 4  
REVISION: 12/9/14

1.5" ODOT ITEM 448, TYPE 1,  
ASPHALT CONCRETE SURFACE  
COURSE FOR PARKING LOTS,  
DRIVES AND REPAIR AREAS

3" ODOT ITEM 301 FOR PARKING  
LOTS, 4" FOR DRIVE AND REPAIR  
AREAS

6" MIN. ODOT ITEM 452 CONCRETE  
FOR PARKING LOTS, 8" MIN IN REPAIR  
AND TRUCK TRAFFIC AREAS

JOINT SEAL PER  
ODOT 705.04  
(ALL SIDES)

CONCRETE WALK OR DRIVE  
REPLACEMENTS SHALL  
INCORPORATE COMPLETE  
BLOCKS, SEE SIDEWALK DETAIL

EXIST. ASPHALT  
DRIVE OR WALK

4" ODOT ITEM 304  
AGGREGATE BASE

4" ODOT ITEM 304 AGGREGATE  
BASE FOR PARKING LOTS,  
6" FOR DRIVE AND REPAIR  
AREAS

UNDISTURBED  
EARTH

COMPACTED ODOT  
ITEM 304 FOR  
TRENCH BACKFILL

12" MINIMUM BEYOND TRENCH  
LIMITS WHERE APPLICABLE, TYP.

GENERAL PAVEMENT NOTE:

1. THICKNESSES SHOWN ARE MINIMUM. CONTRACTOR TO MATCH EXISTING PAVEMENT IN REPAIR AREAS.
2. ALL AGGREGATES SHALL BE CRUSHED, VIRGIN LIMESTONE.
3. ALL PAVEMENT INSTALLATION/REPAIR SHALL BE WITNESSED BY THE LOCAL INSPECTOR. A PROOFROLL USING A TRI-AXLE TRUCK LOADED WITH 15 TONS OF STONE WILL BE REQUIRED FOR AREAS LARGER THAN 300 S.F.

COMMERCIAL ASPHALT OR CONCRETE DRIVEWAY  
N.T.S

CITY OF BARBERTON  
STANDARD DRAWING ROAD 5  
REVISION: 12/9/14

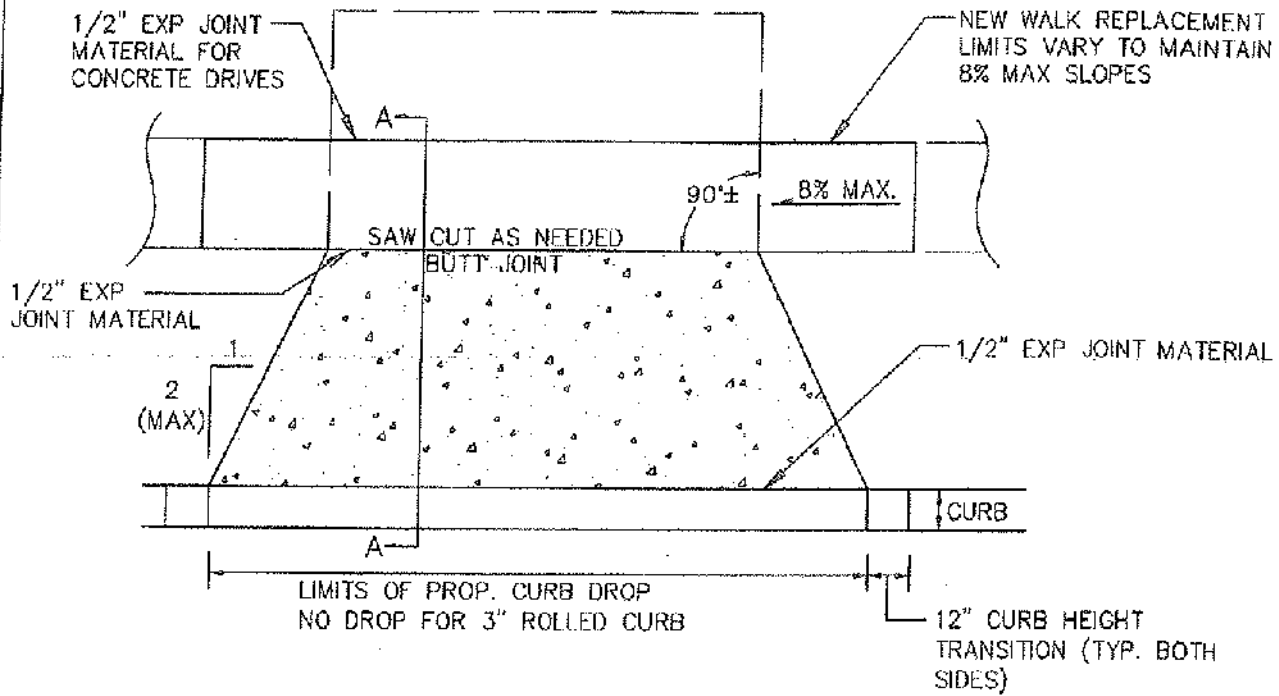

DRIVEWAY APRON  
N.T.S.

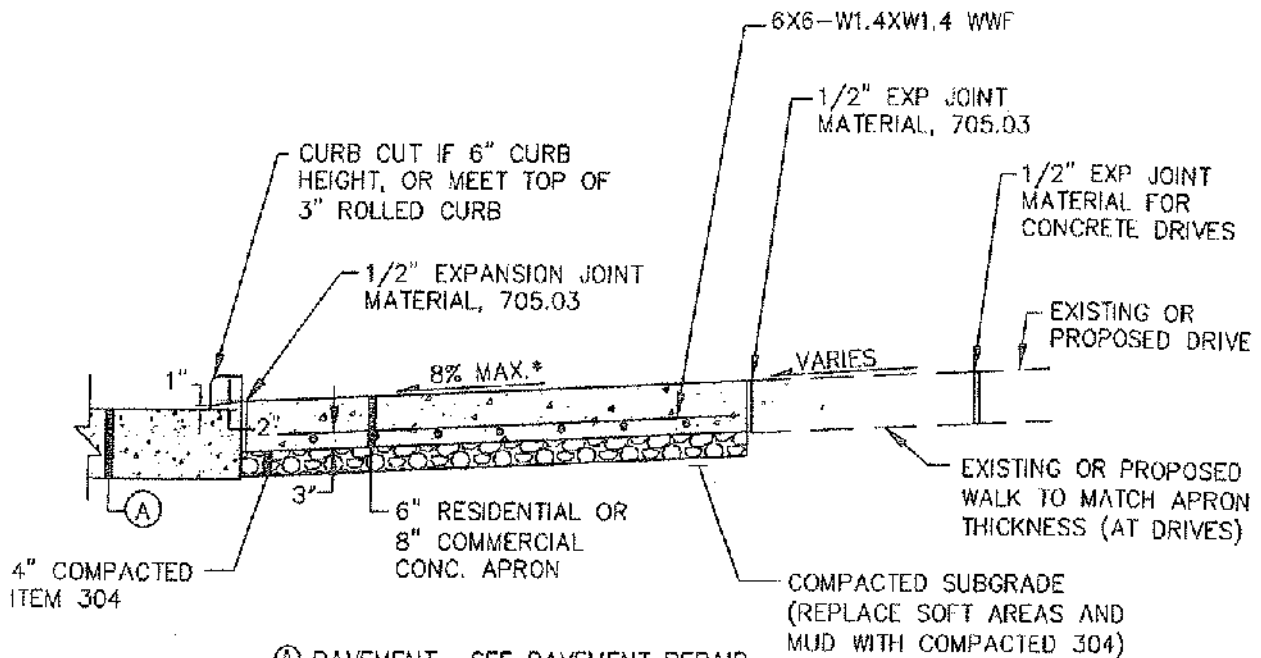

(A) PAVEMENT - SEE PAVEMENT REPAIR  
DETAILS FOR SECTION COMPOSITION

\*SITE PLAN AND DRIVE  
SLOPES TO BE  
COORDINATED TO MAINTAIN  
SLOPES LESS THAN 8%

CURB DROP DETAIL, A-A  
N.T.S.

CITY OF BARBERTON  
STANDARD DRAWING ROAD 6  
REVISION: 12/9/14

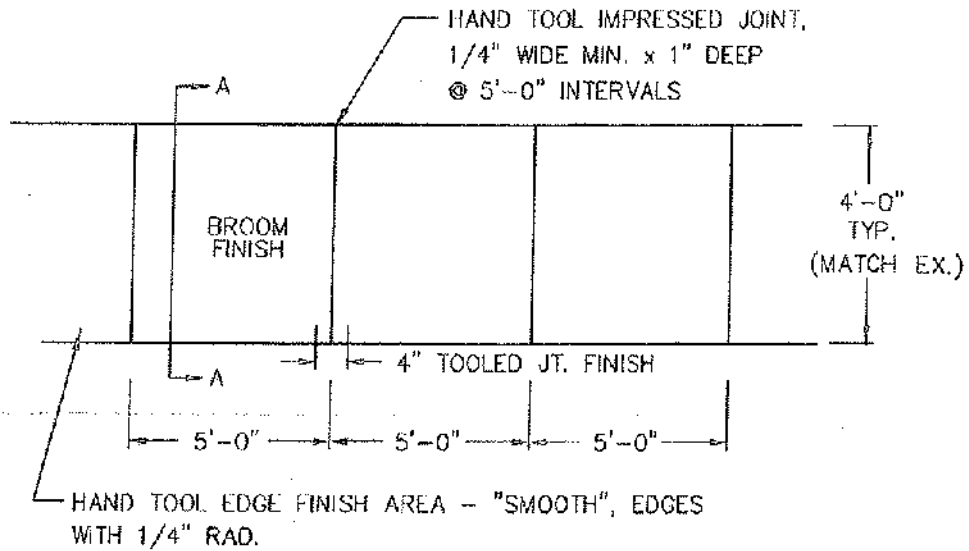

PLAN VIEW  
NOT TO SCALE

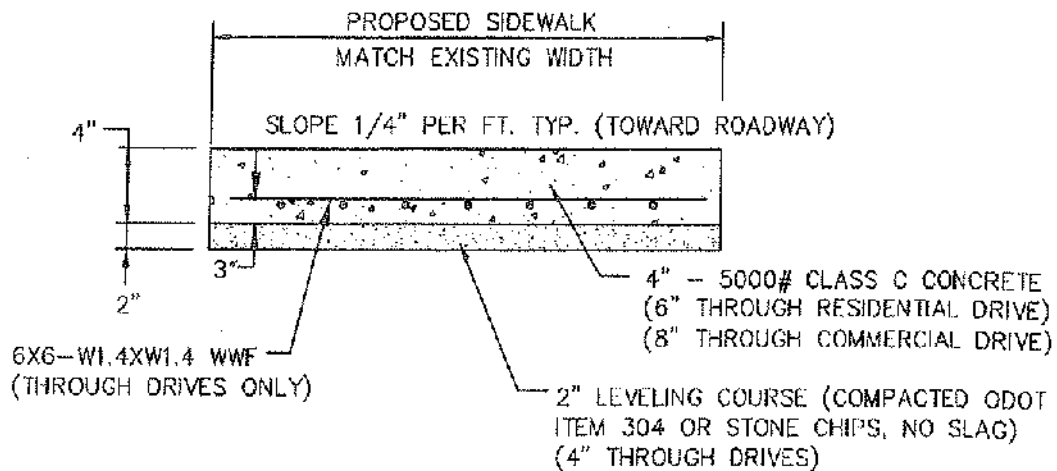

A SECTION  
NOT TO SCALE

NOTE: EXPANSION JOINT SHALL BE PLACED AT FIFTY FOOT (50') INTERVALS AND SCORE MARKS SHALL BE AT FIVE FOOT (5') INTERVALS. CONSTRUCTION SHALL BE IN ACCORDANCE WITH O.D.O.T. ITEM 608. EXPANSION MATERIAL SHALL BE 1/4" THICK (MIN) AND CONFIRM TO ODOT 705.03.

CONCRETE SIDEWALK  
N.T.S

CITY OF BARBERTON  
STANDARD DRAWING ROAD 7  
REVISION: 12/9/14



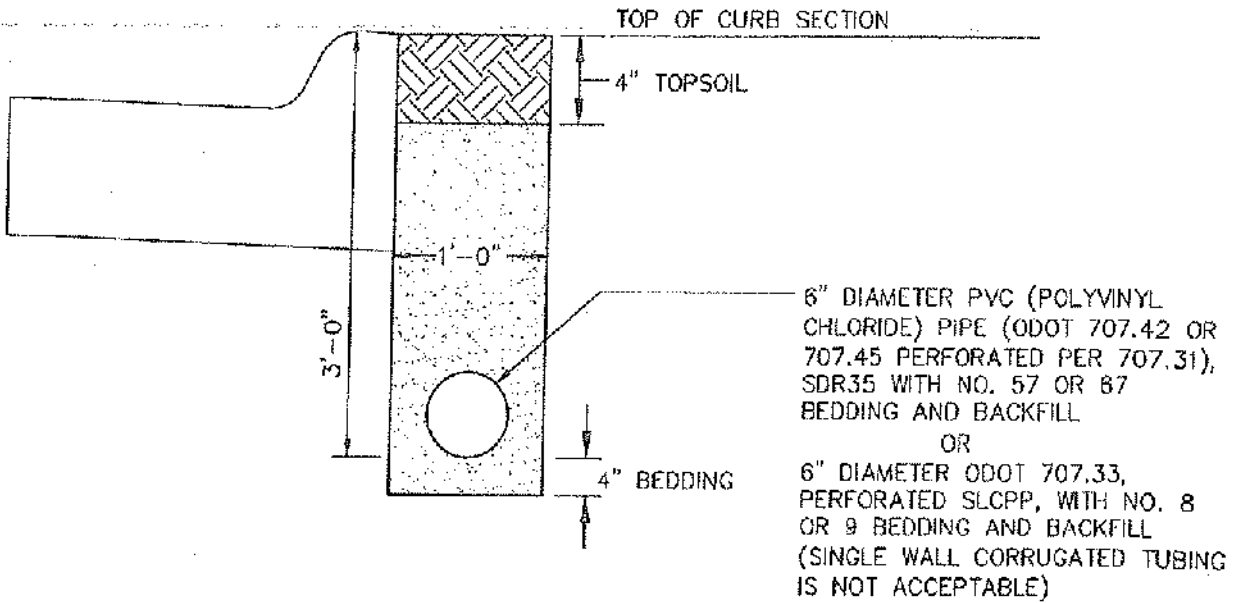

NOTE: UNDERDRAIN MAY BE LOCATED DIRECTLY UNDER CURB. USE HEAVY DUTY FERNCO STYLE REPAIR COUPLINGS WITH STAINLESS STEEL BAND CLAMPS. MAINTAIN FLOWLINE OF EXISTING UNDERDRAIN IF REPAIRED.

UNDERDRAIN DETAIL

N.T.S

CITY OF BARBERTON  
STANDARD DRAWING ROAD 8  
REVISION: 12/9/14

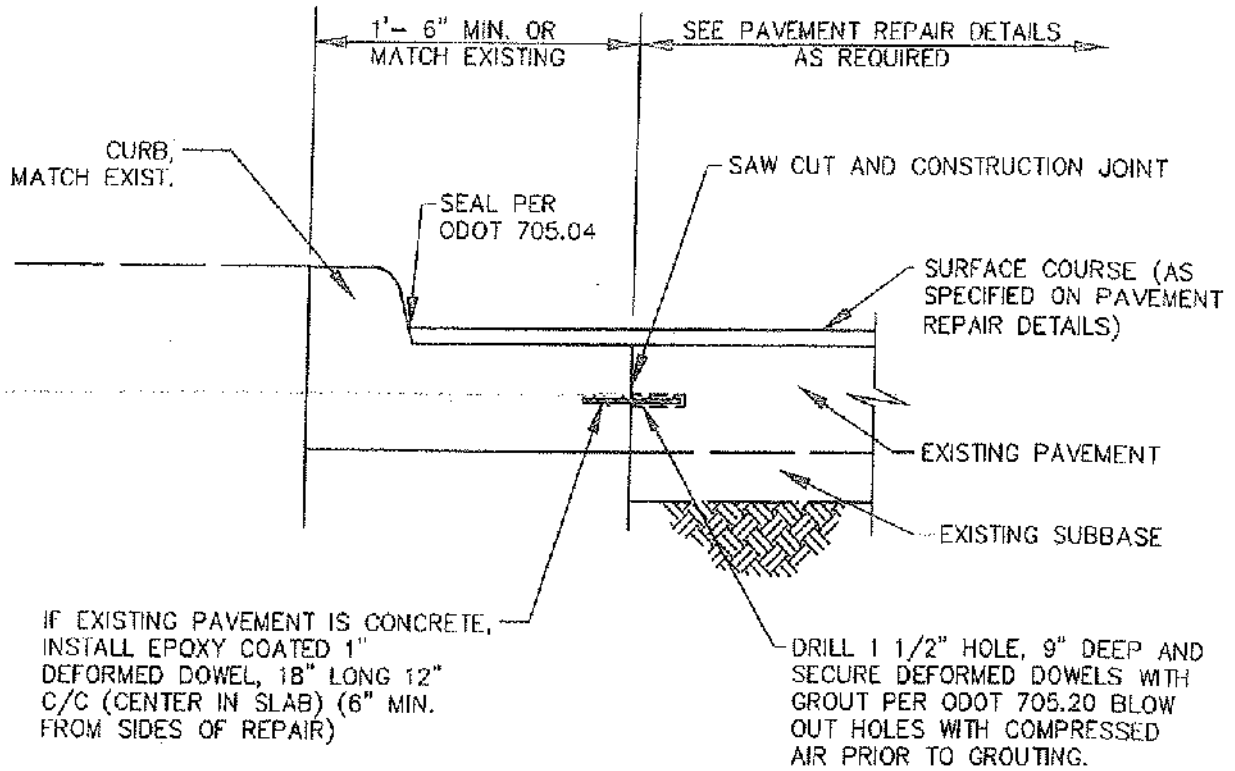

INTEGRAL CONCRETE CURB REPAIR DETAIL  
N.T.S.

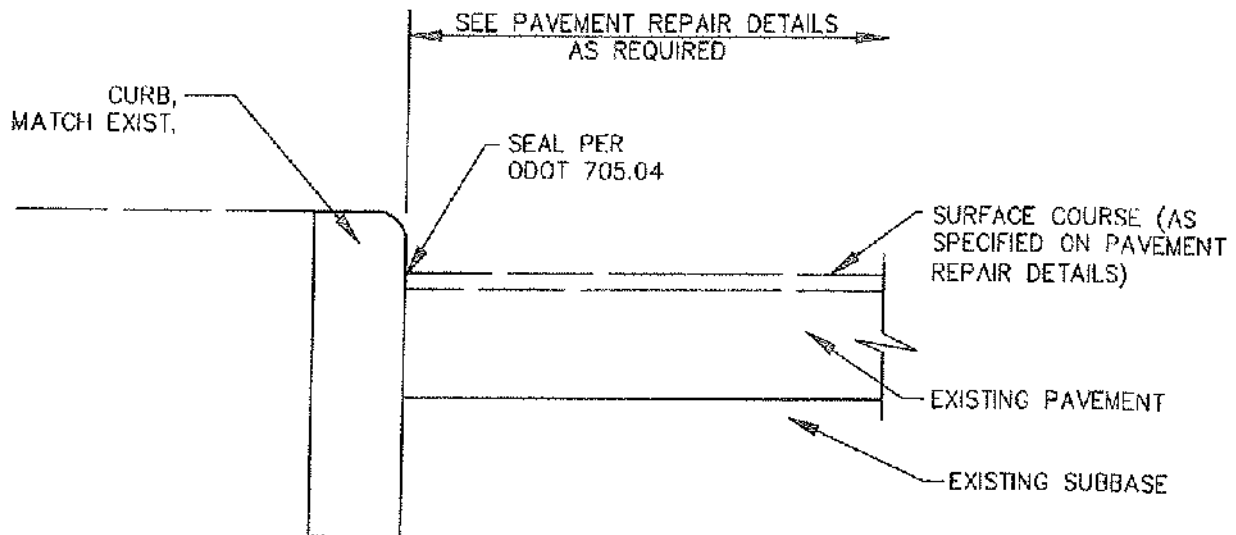

6" X 18" CONCRETE CURB REPAIR DETAIL  
N.T.S.

CITY OF BARBERTON  
STANDARD DRAWING ROAD 9  
REVISION: 12/9/14

### **Water Service Regulations;**

The City of Barberton has the responsibility to replace and/or repair the water main and service line which includes; water main, corporation stop, service line and curb stop – including the curb box stem and cap assembly. The COB does not own or maintain the service line from the curb stop outflow fitting to the Water Meter shutoff valve, but the COB owns and maintains the water meter assembly which includes the meter body, meter head/wiring, meter yoke and MIU.

The City of Barberton has in place some Rules and Regulations regarding the Homeowner/Residents service lines, even though we do not own them we (COB) have jurisdiction over them since they are part of the Distribution system. Some of the rules we enforce are listed below;

#### **Water Service Lines;**

- 1) When a service line is caused to leak; by being hit, the ground or line being disturbed in any way or by any means, the City of Barberton Water Distribution Garage or Water Treatment Plant will be notified immediately. The Contractor(s), Resident or Homeowner is not to turn off the water curb stop, only qualified COB Employees are allowed to make such shutoffs regardless of the size or nature of the leak. Upon arrival COB Employees will determine the action to be made.
- 2) When it is determined that the leak is on the homeowner side and the line is galvanized or plastic, the line must be completely replaced and not "spot" repaired. No such spot repair is acceptable on these types of lines.
- 3) Service lines being replaced must be K Copper (no less than ¾"), ran in a straight line, 48" deep, no fittings unless the line is more than 100' in length. All fittings must be "flared" and no compression fittings are acceptable unless approved by the water purveyor (COB).
- 4) In the event that the line leaking is K Copper, a "spot repair" will be accepted. All copper that has been crimped, crushed or distorted in any way will be cut out and replaced with new K Copper, fittings are acceptable only if they are "flared", no compression fittings will be allowed except upon approval of the COB Inspector.
- 5) After repair or replacement of the service line, an appropriate Inspector or representative employed by the COB will be contacted for water service approval. Inspection must be made before the service line is activated and checked for leaks before burial. In the event no representative from the COB is available the excavation site will be left open until inspection is made, if the repair/replacement is buried before approval the Contractor will be required to re-excavate and expose the line for proper inspection -- No Exceptions.

These Regulations are SOP for the Water Distribution Garage and can only be changed at the sole discretion of the COB and its designated Employee(s).

The City of Barberton has Rules And Regulations Governing the other components of the Distribution system which are ; water mains, water valves and fire hydrants.

**Water Mains/Water Valves/Fire Hydrants;**

In the event of a hit, disturbed or made to leak COB water main, water valve or fire hydrant the Contractor or party(s) involved should immediately contact the COB Water Distribution Garage or Water Treatment Plant. The party(s) involved should make no attempt to shut off or stop the flow of water in any manner, this would include not turning or touching any valves, curb stops or hydrant stops unless a COB Employee or it's representative are present. In the event of a non-COB Employee water service shut-off to any residences or business a fine or fee can be accessed by the Water Purveyor (COB).

**Non-Potable Water for Contractor(s) use:**

When water is needed for non-potable use the COB has at the Water Pollution Control Center a designated Fire Hydrant for Contractor(s) use. The hydrant is equipped with a metered-backflow device, 2" valve and 2" fire hose for top or bottom filling. Contractor (s) will be required to fill out the proper paperwork which includes; Company name, billing address, meter reading before/after usage.

Absolutely No water will be taken from a COB fire hydrant for Contractor use unless approved by the Water Purveyor (COB). If hydrant usage is approved by the COB , a \$100.00 backflow installation/setting fee will be accessed plus all water used will be metered and the Contractor charged accordingly.

If you are caught using a fire hydrant without approval by the COB, a fine of up to \$500.00 may be applied.

**Sanitary/Storm Sewers ;**

When a storm or sanitary sewer is caused to fail by being hit, disturbed or damaged in any manner, the COB Street or Sewer Departments will be contacted immediately. The COB will determine what the damage is and action to be taken either by the COB or Contractor(s). The COB will also conduct inspections after repairs/replacement of said lines.